

Find the Best Location for Your Sculpture

The sculpture is kinetic and wind driven. Selecting the right location will determine its performance. Wind currents, like water in a stream, occur in pools, eddies and steady currents—varying the sculpture's performance. "Wind shadows" may be caused by buildings, walls, trees and high bushes. Obstacles may cause neutral areas, preventing the sculpture from moving freely. Walk around your potential location with the mounting pole and surveyors tape attached near the top. Observe where the tape flies horizontally the strongest. The wind usually moves west to east, so it is especially important to have a clear path from the west.



Do not place your sculpture too near objects that can block wind flow.

These include walls, trees, or fences. Find a gentle wind current.

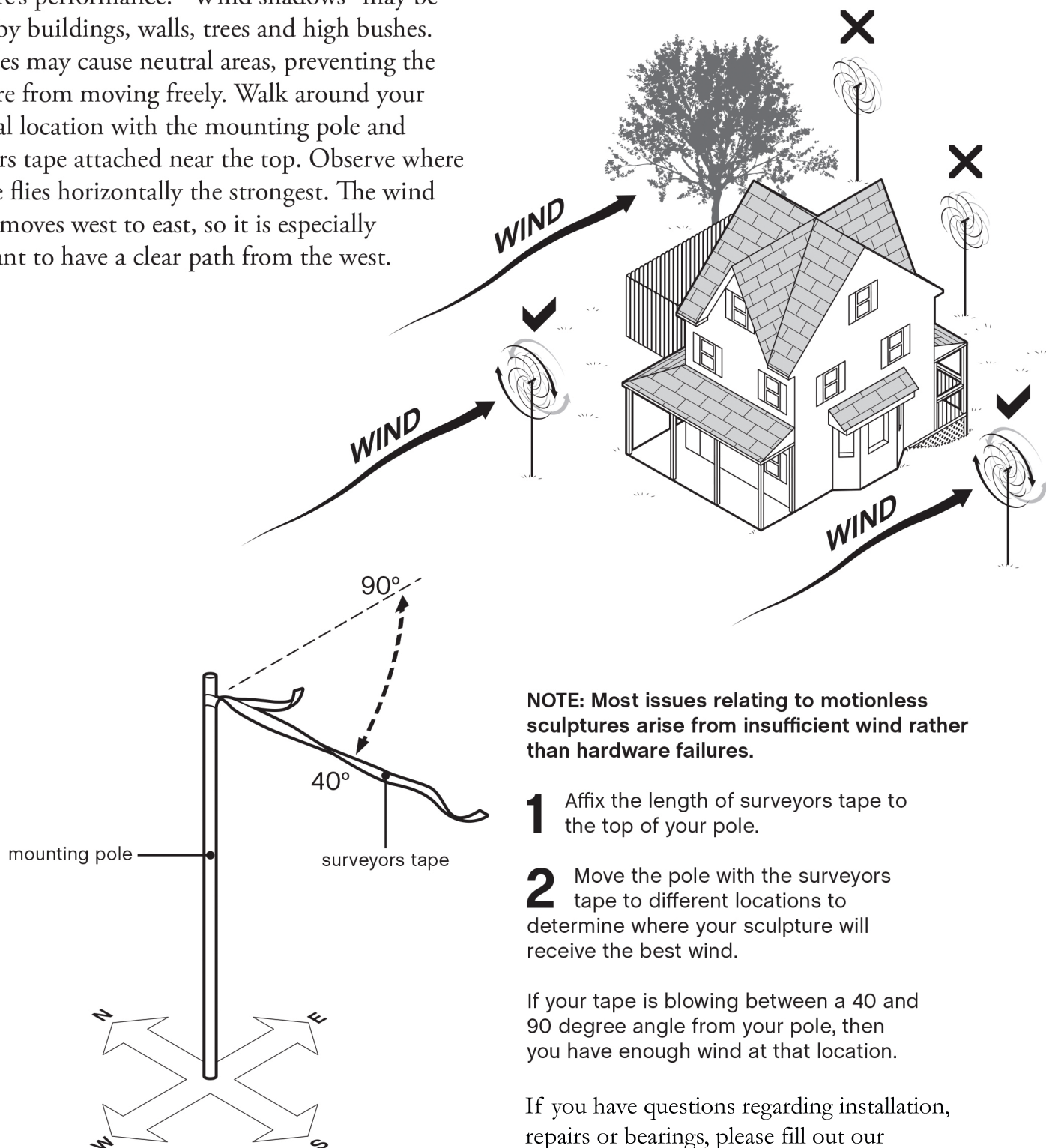

NOTE: Most issues relating to motionless sculptures arise from insufficient wind rather than hardware failures.

- 1** Affix the length of surveyors tape to the top of your pole.
- 2** Move the pole with the surveyors tape to different locations to determine where your sculpture will receive the best wind.

If your tape is blowing between a 40 and 90 degree angle from your pole, then you have enough wind at that location.

If you have questions regarding installation, repairs or bearings, please fill out our "Warranty and Repair Form" at markwhitefineart.com/warranty-repair-form For all other questions, please email info@markwhitefineart.com

Install Ground Stake

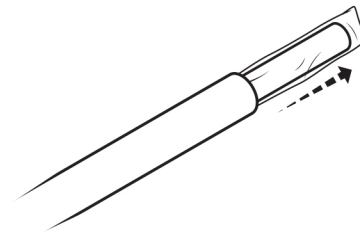

1 Remove your pole from the cardboard shipping tube.

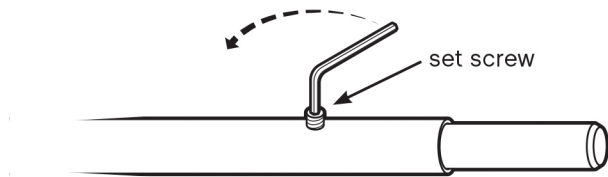

2 Loosen the set screw at the base of your pole using the provided Allen wrench.

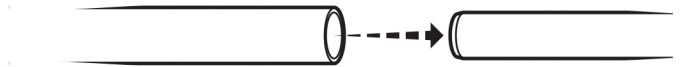

3 Completely remove the ground stake tucked within it.

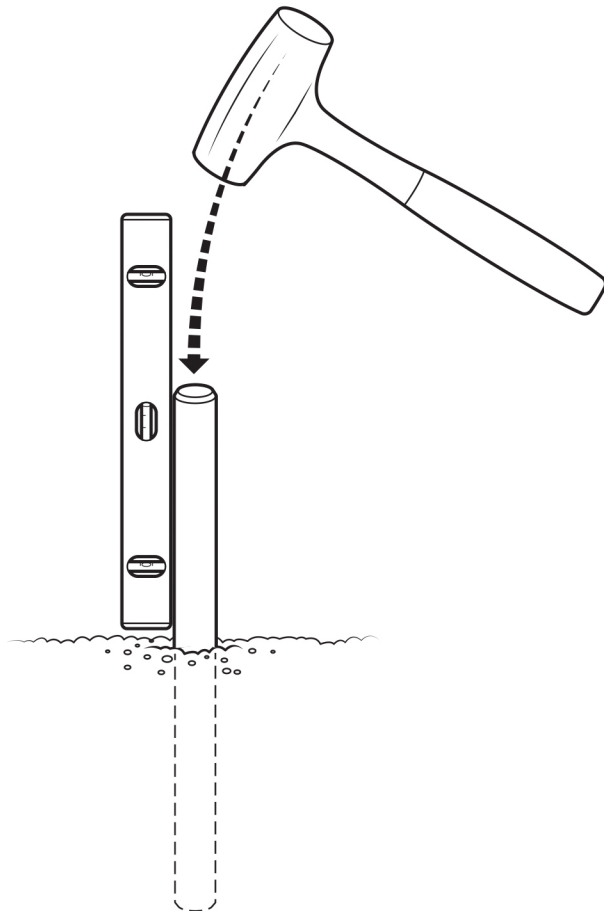

4 Using a mallet or sledge hammer, drive your ground stake at least half-way into the ground. Use a level to get it straight. If the ground is hard, drive a pilot hole or soak the area with water overnight. Be careful not to mushroom the end of the stake while hammering or else the pole will not slip over the ground stake. If the ground stake does mushroom, try flipping the mushroomed side into the ground.

If you have questions regarding installation, repairs or bearings, please fill out our “Warranty and Repair Form” at markwhitefineart.com/warranty-repair-form For all other questions, please email info@markwhitefineart.com

Place Sculpture onto Pole

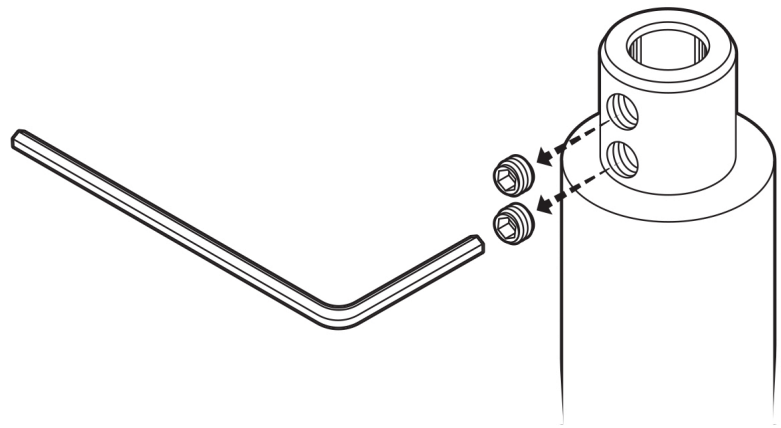
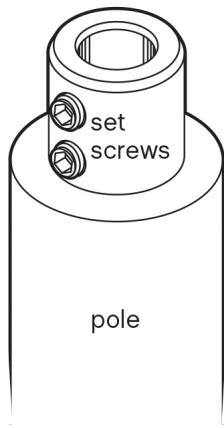

1 Once you've installed your ground stake and pole, notice the small set screw at the top. It should be semi-exposed, sticking out from the pole top opening.

2 Remove these set screws from the top of your pole with the included Allen wrench and set them aside.

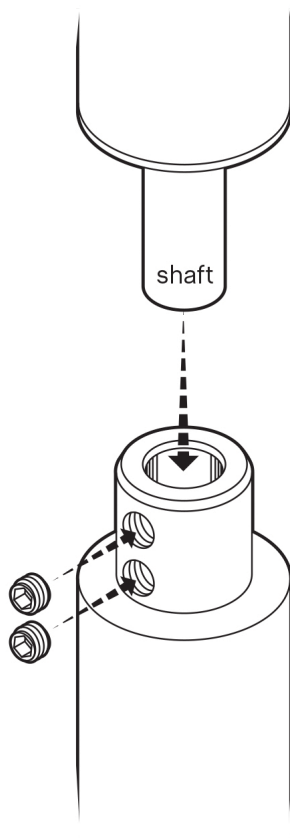

3 Insert the shaft of your wind sculpture into the pole opening.

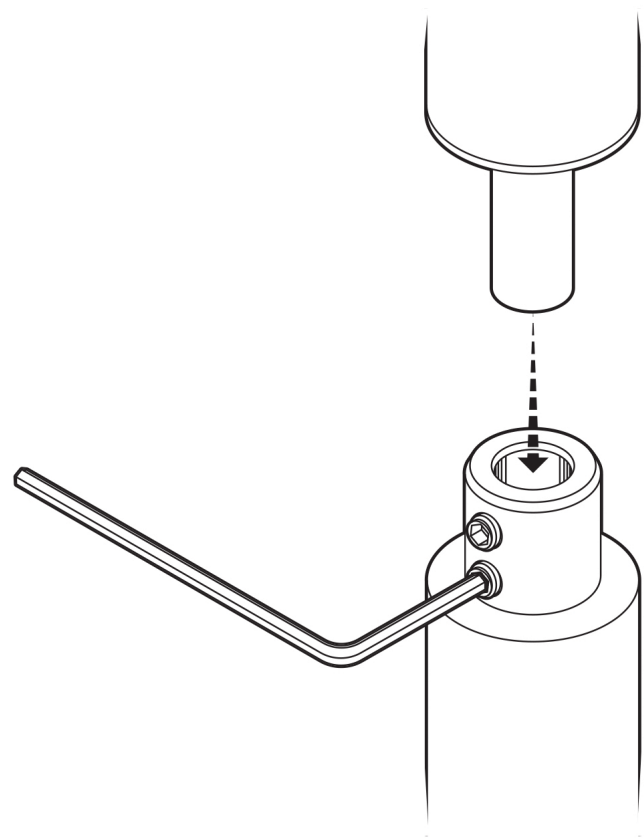

4 Replace the small set screws into the holes and tighten them using the Allen wrench.

If you have questions regarding installation, repairs or bearings, please fill out our "Warranty and Repair Form" at markwhitefineart.com/warranty-repair-form
For all other questions, please email info@markwhitefineart.com

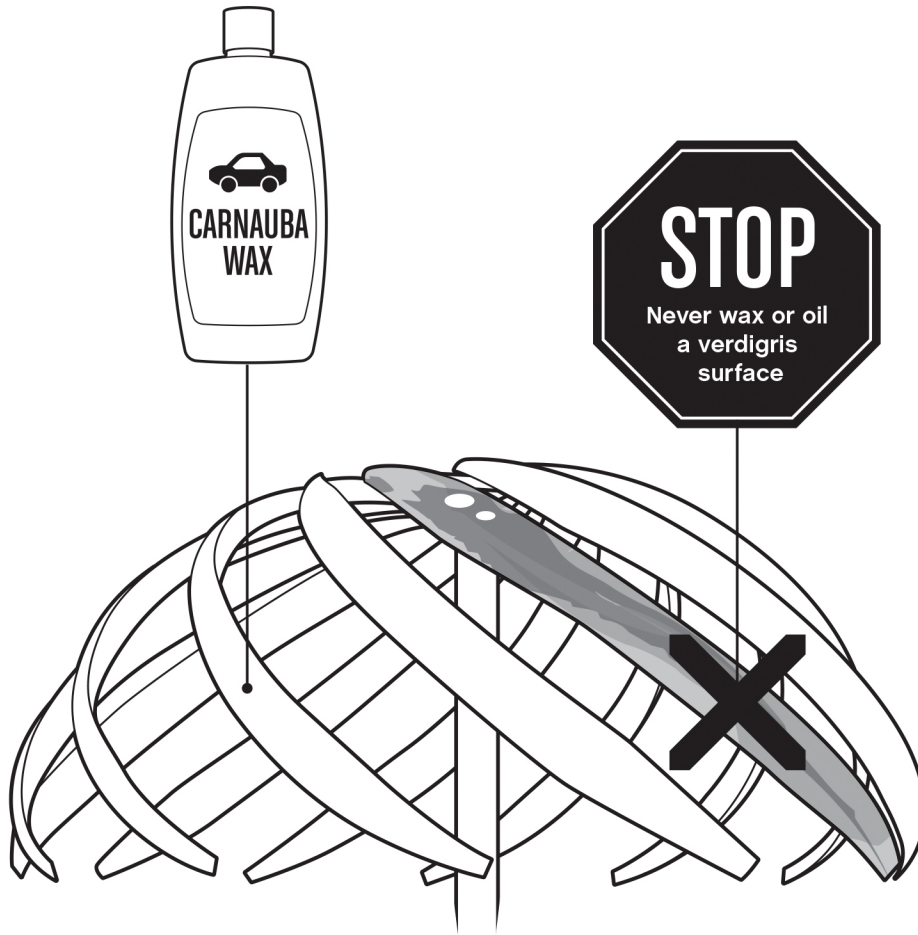

Nature is hard on outdoor finishes. Paint, patina and dye will undergo natural changes, resulting in an aged appearance over time. The finish on your outdoor sculpture contains the very best ultraviolet protection and corrosion inhibitors available. Good maintenance will help retain a new appearance.

Applying quality car/carnauba wax 1-2 times a year will help maintain its original luster. Do not apply wax to blades that have a verdigris patina! Carnauba wax should only be applied to; Bronze, Stainless Steel, Red, Purple, or Teal blades.

⚠ Never wax a verdigris finish or lubricate the bearing!

Wax or oil will permanently discolor the verdigris finish.

We advise bringing your sculpture in during periods of extreme weather. These measures will extend the life of your kinetic sculpture.

Mark White Kinetic Studio offers a LIFETIME WARRANTY on the Kinetic Drive-Train of all Kinetic Wind Sculptures.

The Kinetic Drive-Train is composed of; bearings and solid center rod. All bearings are 100% stainless steel, pre-lubricated, and sealed. (aerospace graded)

The warranty does not cover: Natural patinas and aging of the copper blades and surface oxidation of stainless steel components. Damage or malfunction caused by external factors such as but not limited to; tree branches, lawnmowers, flying debris, etc. Failure to read and follow the provided instructions will void the warranty.

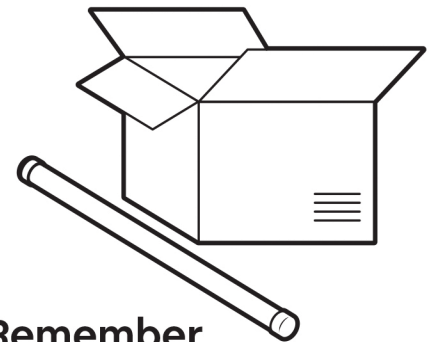

Remember

Save your sculpture's packaging for a few weeks just to be sure there is no cause for return. If you have any difficulty or questions, please call the gallery from which you purchased the sculpture.



**Thank you and enjoy
your sculpture!**

Mark and Sue White

Replace Bearings

1 Remove set screws with allen wrench. Lift sculpture off of pole and place on a soft surface

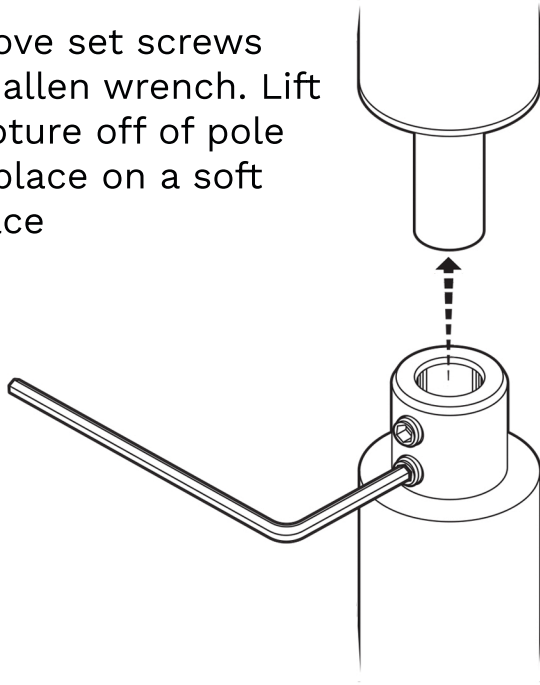

2 Remove "C" clip from bottom using flathead screwdriver



3 Slide bearings and hub off center rod

*Repeat steps 2 and 3 for multi-tier designs

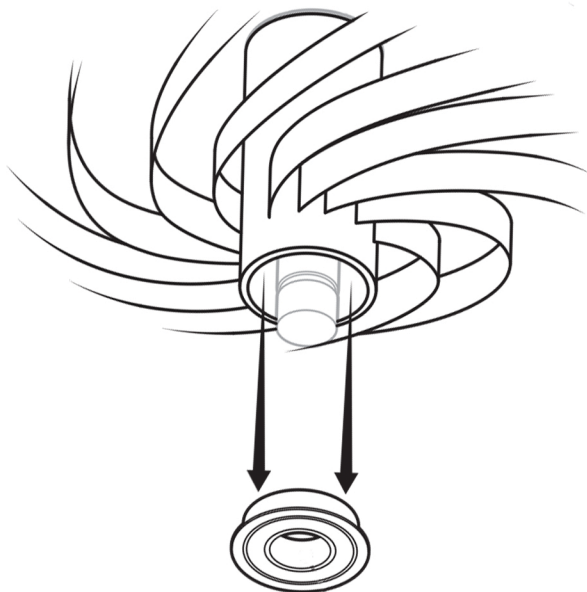

4 Before installing new bearings, clean rod and "C" clips with paper towel

Follow process in reverse order for NEW bearings

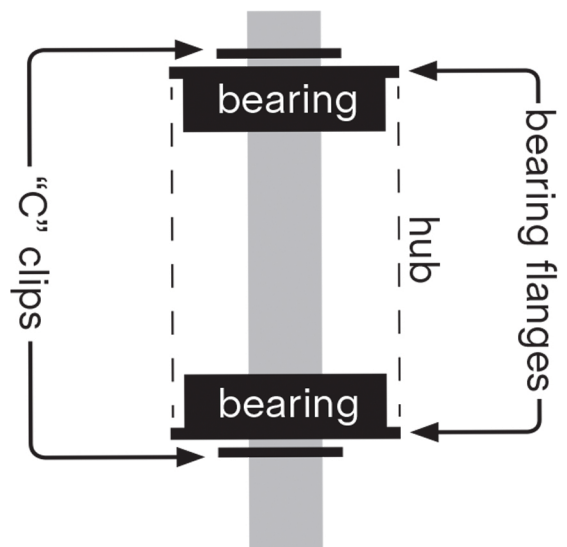

Unlock Set Screw to Allow Rotation

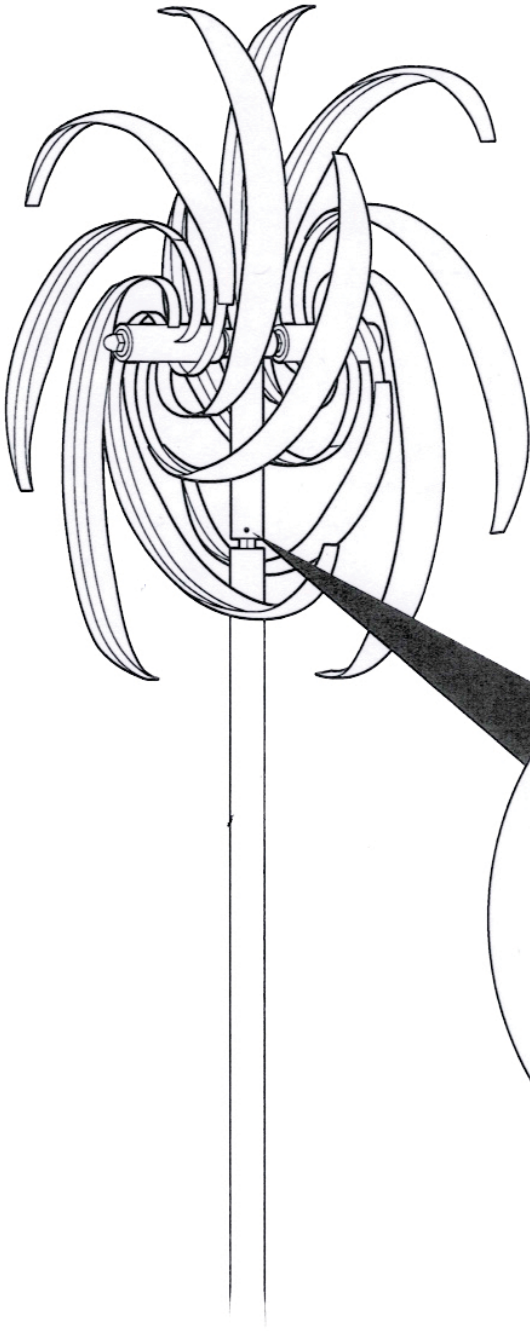

Your sculpture ships with this set screw fully tightened. Unscrew one full turn using the included Allen wrench. This allows the sculpture to rotate in the wind as intended.

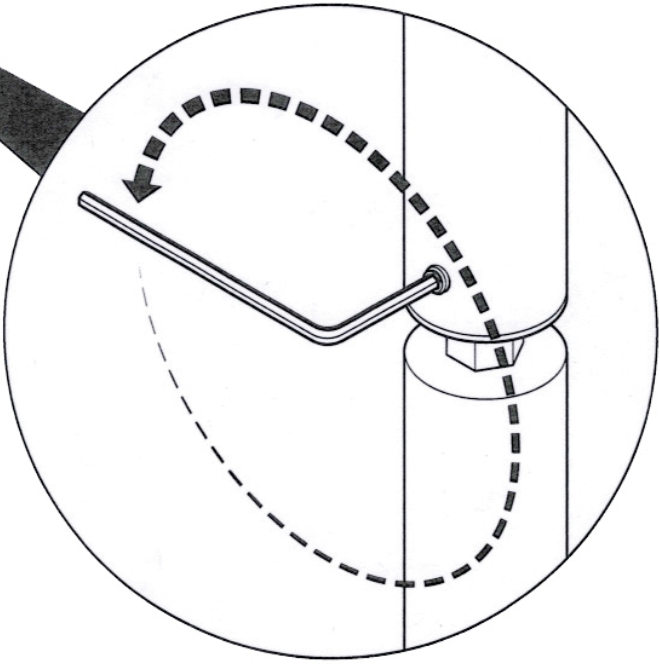

Orb Assembly Instructions

Step 1. Set the two bowl shaped halves onto a padded surface.



Step 2. The solid rod with bearings will come pre-assembled. To attach the two rotating halves, please remove the "C-Clips" and bearings from the rod.
Please take note of the order these parts are assembled.

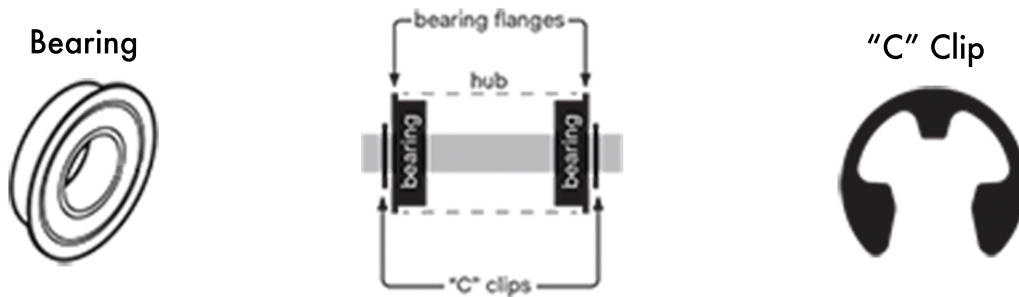

Step 3. Slide the solid rod through the center hub of one half of the sculpture, placing a bearing on top and bottom. To hold into place insert a C-Clip into the groove on the rod, just below the bearing.

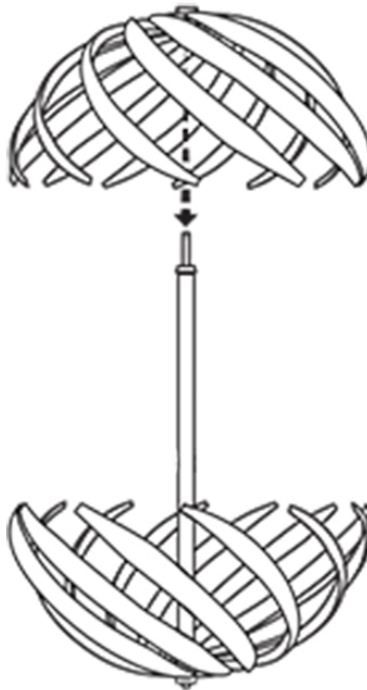

Step 4. Repeat Step 3 for the bottom section of the sculpture. Again, using a C-Clip below the bearing to hold the section in place.

You are now ready to set up your wind sculpture. Please refer to instruction packet for ground stake installation and pole set up.

HOW TO BALANCE YOUR WIND SCULPTURE

BEFORE YOU BEGIN

Choose a calm day with little to no wind. Even a light breeze can affect the balancing process.

If your sculpture already has balancing weight installed, remove all existing weight from the inside of the arm(s) before starting.

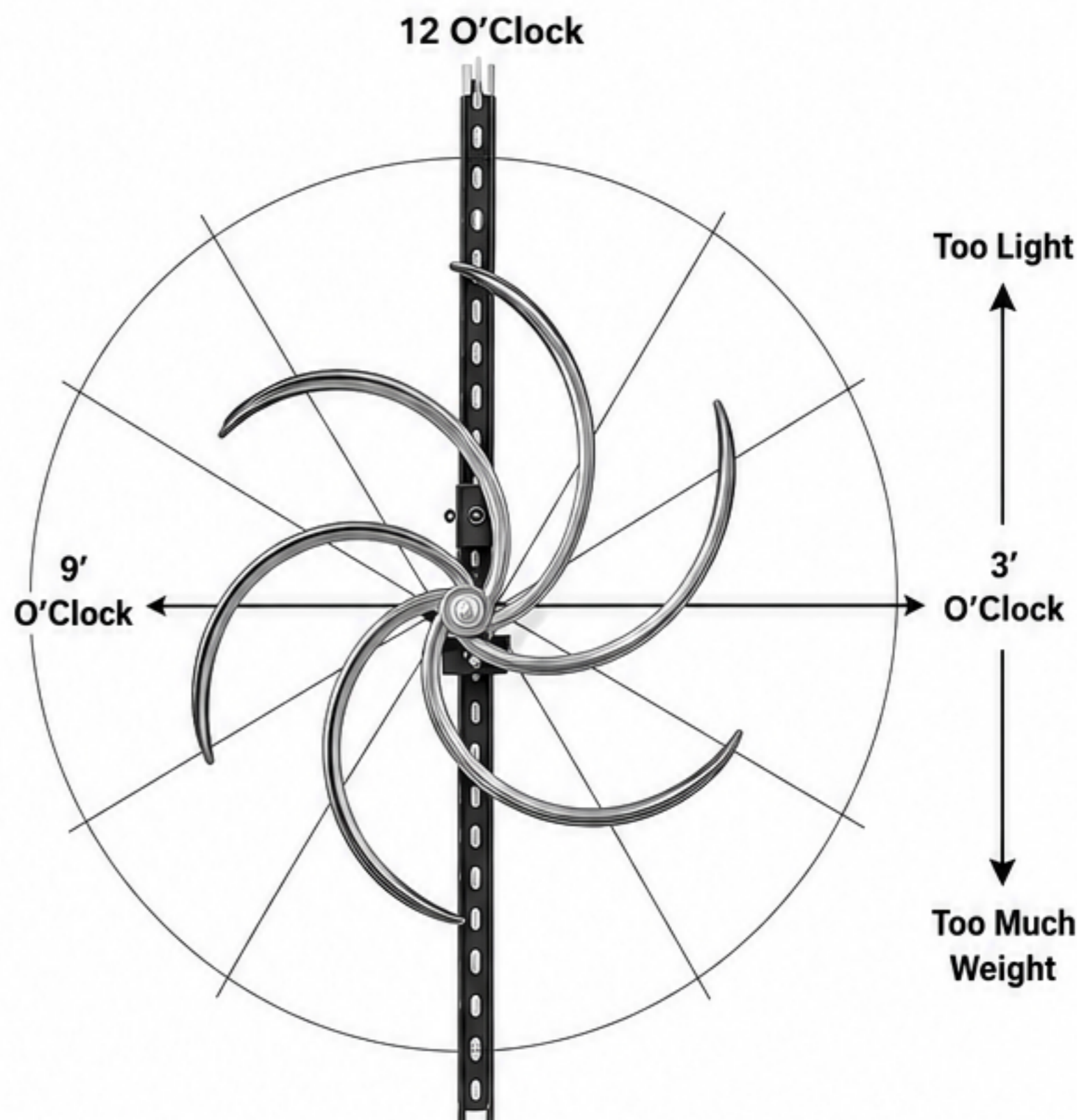

1 CHECK ARM SPACING

Inspect the sculpture and make sure all arms are evenly spaced around the hub. The distance between each arm should be equal, or as close to equal as possible.

2 FIND THE LIGHT SIDE

Gently spin the wheel and allow it to come to a complete stop on its own.

Once it stops, the point that settles at the 12 o'clock position is the light side of the sculpture.

Place a small piece of tape on that arm to mark the light side. Depending on the sculpture, the tape may be positioned closer to the hub or closer to the tip of the arm.

3 MOVE THE LIGHT SIDE TO 3 O'CLOCK

Rotate the wheel until the taped arm is positioned at 3 o'clock.

If the sculpture is out of balance, the taped arm will naturally want to rise back toward the 12 o'clock position. This confirms that the taped arm is the light side and needs additional weight.

4 ADD WEIGHT

Use wire cutters to cut a piece of lead from the provided packet and tape it to the inside of the arm.

Observe the result; ideally, the wheel should tilt downward, indicating that you have slightly too much weight. This ensures a good starting point, from which you can begin trimming the lead in small increments until the wheel is balanced.

This will help permanently secure the weight and ensure years of reliable performance.

5 TEST AT 3 O'CLOCK AND 9 O'CLOCK

Your goal is for the taped arm to remain stationary when positioned at both 3 o'clock and 9 o'clock.

TEST 1: 3 O'CLOCK

- Place the taped arm at 3 o'clock and release it.
- If it rises toward 12 o'clock, the arm is still too light.
- If it falls toward 6 o'clock, the arm is too heavy.
- If it remains in place, proceed to the next test.

TEST 2: 9 O'CLOCK

- Place the taped arm at 9 o'clock and release it.
- If it rises toward 12 o'clock, the arm is still too light.
- If it falls toward 6 o'clock, the arm is too heavy.
- If it remains in place, the sculpture is properly balanced.

Continue making small adjustments until the taped arm stays in position at both 3 o'clock and 9 o'clock.

6 PERMANENTLY SECURE THE WEIGHT

1. Remove the paper backing from the adhesive on the lead weight.
2. Attach the weight in the exact location where you achieved balance.
3. Using the supplied clear coat and cotton swabs, apply a generous coating around the edges of the weight.
4. Make sure the clear coat flows slightly underneath the weight and adhesive.